

COMBIVERT

F4-C



INSTRUCTION MANUAL

CUSTOM CONTROL



Important Note: The user should read this manual completely prior to operating the inverter



This instruction manual must be made available to all users. Before working with this unit the user must be familiar with it. This is especially true for the attention, safety and warning guides. The meaning of the icons used in this manual are:



**Danger
Warning
Caution**



**Attention,
observe at
all costs**



**Information
Help
Tip**

COMBIVERT F4-C Instruction Manual

Table of Contents

1.	Installation and connection	2
1.1	Definition of control terminal strip	2
1.2	Connection of the control signals	3
1.3	Digital inputs	3
1.4	Analog inputs	3
1.5	Outputs	3
2.	Operation of the inverter.....	4
2.1	Interface operator	4
2.1.1	Option operators	4
2.1.2	Keypad	5
2.2	Parameter summary	6
2.3	Password input	6
2.4	Operating display	7
2.5	Basic adjustment of the drive	8
2.6	Special adjustments	10
2.7	The "Drive Mode"	17
2.7.1	Start / Stop "Drive Mode"	17
2.7.2	Changing direction of rotation	17
2.7.3	Speed setting	17
2.7.4	Leaving "Drive Mode"	17
2.8	The "Application mode".....	18
3.	Error diagnosis	19
4.	Glossary	21
5.	Quick reference	23
6.	Passwords	24

1. Installation and connection

1.1 Definition of the control terminal strip

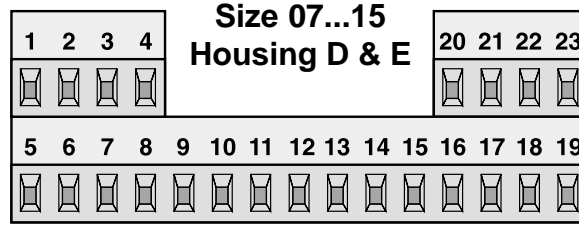

Size 13 and greater



PIN	Function	Description
1	NO contact	Relay output
2	NC contact	Function see parameter CP.22
3	Switch contact	(factory setting: fault indication)
4	Fixed frequency 1	A signal at 4 and 5 gives fixed frequency 3, no signal and the speed reference becomes the analog input
5	Fixed frequency 2	
6	DC Braking	This input activates DC braking
7	Energy saving	Output voltage to the motor is reduced 70%
8	REF+	Differential input +/- 10V; Voltage is added/subtracted to REF
9	REF-	
10	Forward	Forward signal (has priority over reverse)
11	Reverse	Reverse signal
12	Digital output	Digital output switches when $f_{actual} = f_{set}$
13	Digital common	Common terminal for all digital inputs and outputs
14	+15V	Internal supply voltage for digital inputs and output (max. load 100mA)
15	Analog output	Proportional to the actual frequency (0...10V = 0 to 102.4Hz)
16	+10V	Regulated analog supply voltage for speed reference
17	REF	Analog input for speed reference 0...10V, 0...20mA, 4...20mA
18	Analog common	Common for the analog inputs and output
19	Control release	Inverter enable/disable
20	Reset	Inverter fault reset
21	NO contact	Relay output - frequency dependent switch Relay switches when the output frequency exceeds the level set in parameter CP.23
22	NC contact	
23	Switch contact	

1.2 Connection of the control signals

In order to prevent a malfunction caused by interference voltages on the control inputs, the following steps should be observed:



- Use shielded/twisted cables
- Connect shields to earth ground only at the inverter
- Lay control and power wires **separately** (about 8" apart)
- Control and power wires should cross at a right angle

1.3 Digital Inputs

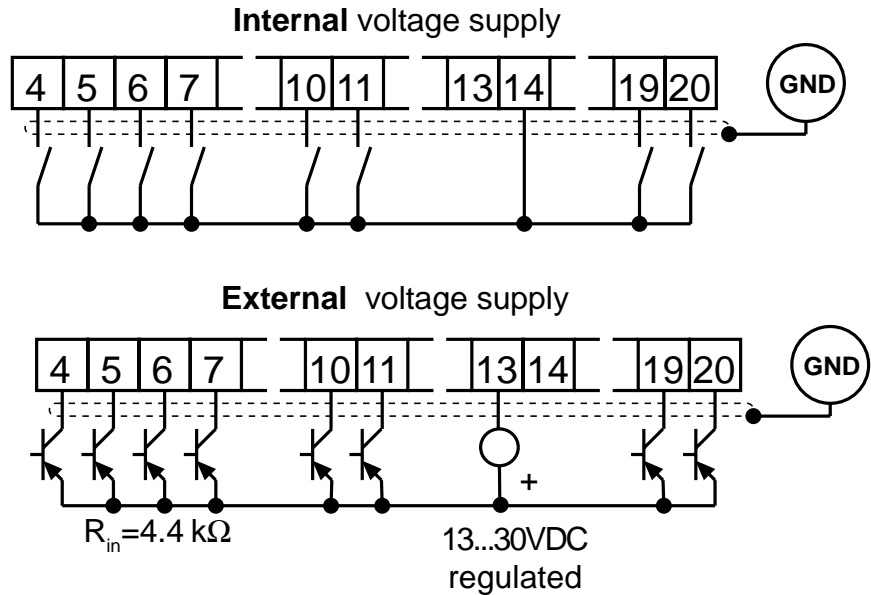

1.4 Analog Inputs

Analog Speed Reference
(see CP.24)

Connect unused analog input to common to eliminate noise signals

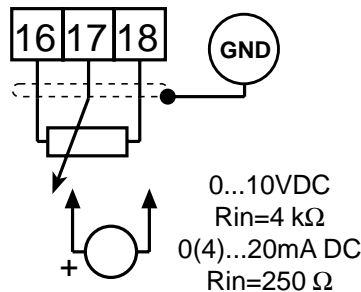

Bi-directional Speed Reference

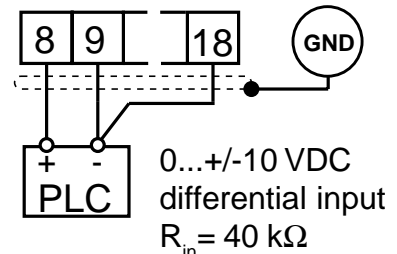

1.5 Outputs

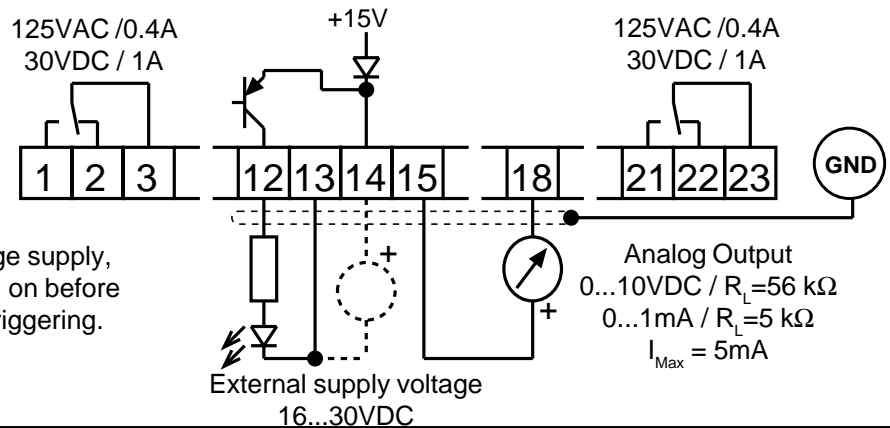

When using an external voltage supply, the external supply should turn on before the inverter to prevent false triggering.

Operation of the Unit

2. Operation of the inverter

When running the inverter without an operator, it runs with the last stored values or factory setting. The red LED remains on constantly when the unit is connected to supply voltage and functioning normally. The LED will begin to flash in the event of an error condition. To facilitate parameter adjustment and inverter monitoring, a keypad/display operator is required. To prevent malfunctions, the inverter must be brought into **nOP** status before connecting/disconnecting the operator (remove the signal at the control release terminal 19). The operator is available in different versions:

2.1 Digital operator 00.F4.010-2009

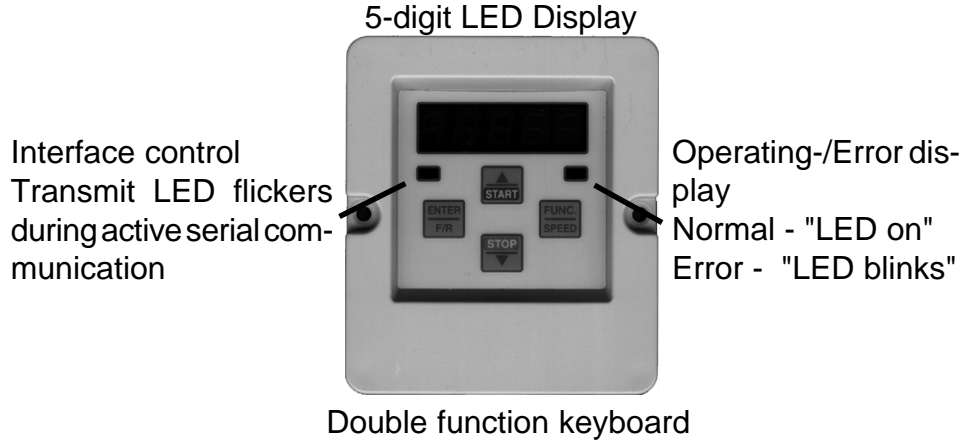

2.1.1 Serial operators 00.F4.010-1009

The Interface operator contains an additional isolated RS232/RS485-communication port for serial communication to and from the inverter.

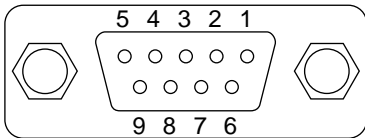

PIN	RS485	Signal	Meaning
1	–	–	reserved
2	–	TxD	Transmit signal/RS232
3	–	RxD	Receive signal/RS232
4	A'	RxD-A	Receive signal A/RS485
5	B'	RxD-B	Receive signal B/RS485
6	–	VP	Voltage supply-Plus +5V ($I_{max} = 10 \text{ mA}$)
7	C/C'	DGND	Data reference potential
8	A	TxD-A	Transmit signal A/RS485
9	B	TxD-B	Transmit signal B/RS485

Additional operators are available for the COMBIVERT F4 inverters for various types of serial communication protocols. Consult KEBCO for LON, CAN, Profibus, DIN66019, and InterBus S operators.

2.1.2 Keypad

When switching on the inverter, the value of parameter CP.1 appears. (See Drive mode to switch the keyboard function)

The **function key** (FUNC) changes between the parameter value and parameter number.



With **UP** (▲) and **DOWN** (▼) the value of the parameter number is increased / decreased .

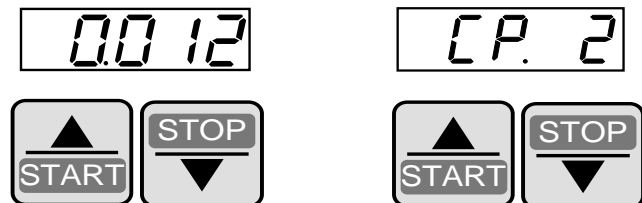

Generally, when a value is changed, parameter values are immediately accepted and stored nonvolatile. With some parameters it is necessary to press **ENTER** after changing the value in order for the new value to be stored nonvolatile. When this type of parameter is changed, a decimal point appears behind the last digit.

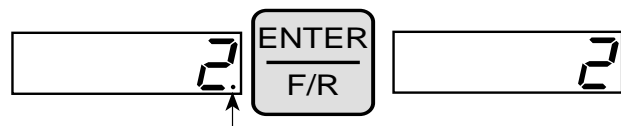

If a drive fault occurs during operation, the current display changes to the drive fault message. The drive fault message in the display is reset by pressing **ENTER**.

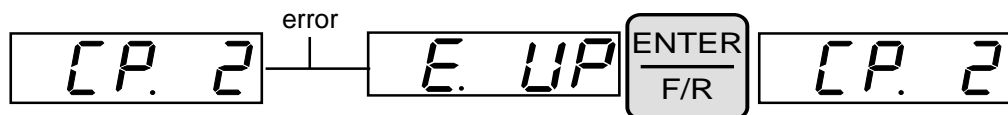

Pressing **ENTER** only resets the fault message in the display. In order to reset the fault itself, the cause must be identified and removed and a reset signal given on terminal 14 or a power-on reset (cycle supply voltage off and then on) must occur. In the Inverter status display (CP. 2) the fault is still displayed until the inverter has been reset through the steps listed above.

Operation of the Unit

2.2 Parameter Summary

Display	Parameter	Adjust. range	Resolution	Factory setting
CP. 0	Password input	0...9999	1	-
CP. 1	Actual frequency display	Read only	0.1 Hz	-
CP. 2	Inverter status display	Read only	-	-
CP. 3	Actual load	Read only	1 %	-
CP. 4	Peak load	Read only	1 %	-
CP. 5	Rated frequency	0...409.58 Hz	0.0125 Hz	50.0 Hz
CP. 6	Boost	0...25.5 %	0.1 %	2 %
CP. 7	Acceleration time	0.01...300 s	0.01 s	10 s
CP. 8	Deceleration time	0.01...300 s	0.01 s	10 s
CP. 9	Minimum frequency	0...409.58 Hz	0.0125 Hz	0 Hz
CP.10	Maximum frequency	0...409.58 Hz	0.0125 Hz	70 Hz
CP.11	Fixed frequency 1	0...409.58 Hz	0.0125 Hz	5 Hz
CP.12	Fixed frequency 2	0...409.58 Hz	0.0125 Hz	50 Hz
CP.13	Fixed frequency 3	0...409.58 Hz	0.0125 Hz	70 Hz
CP.14	Max. ramp current	10...200 %	1 %	140 %
CP.15	Max. constant current	10...200 %	1 %	200 %
CP.16	Speed search	0...7	1	0
CP.17	Voltage stabilization	150...649 V,oFF	1 V	oFF
CP.18	Slip compensation	-2.50...2.50	0.01	0=oFF
CP.19	Autoboost	-2.50...2.50	0.01	0=oFF
CP.20	DC-braking	0...9	1	0
CP.21	Braking time	0...100 s	0.01 s	10 s
CP.22	Relay output	0...25	1	2
CP.23	Frequency level	0...409.58 Hz	0.0125 Hz	4 Hz
CP.24	Reference Signal	0...2	1	0

2.3 Password input

CP. 0



From the factory, the frequency inverter is supplied without password protection, this means that all parameters can be adjusted. After programming, the unit can be protected against unauthorized access thus preventing the values from being changed.

Locking the CP-Parameters (Read only)

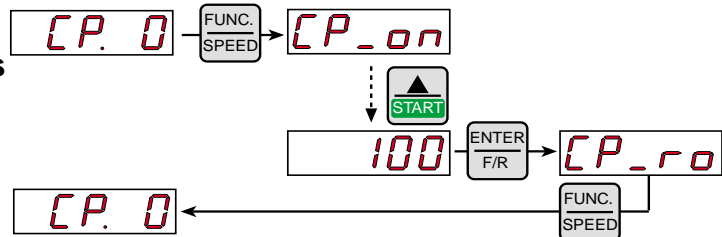

Releasing the CP-Parameters

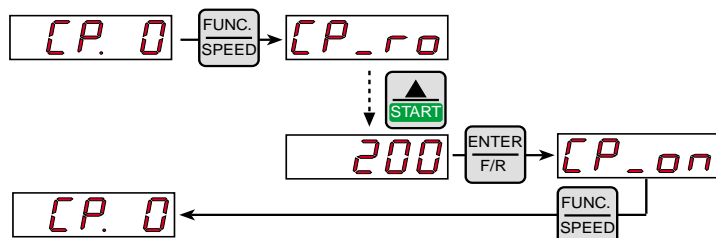

2.4 Operating display

The 4 parameters below can be used to monitor the frequency inverter's operation.

Actual frequency display



Display of the actual output frequency with a resolution of 0.0125 Hz. The rotation of the inverter is indicated by the sign.

Examples: Output frequency 18.3 Hz, rotation forward
 Output frequency 18.3 Hz, rotation reverse

Inverter status display

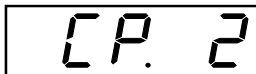

The status display shows the actual working conditions of the inverter. Possible displays and their meanings are:

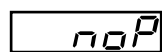

" no Operation " control release (terminal 19) not connected, modulation switched off, output voltage = 0 V, drive is disabled.

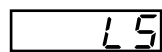

" Low Speed " no rotation signal F or R (terminal 10 or 11), modulation switched off, output voltage = 0 V.

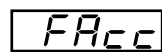

" Forward Acceleration " drive accelerates with a forward direction of rotation.



" Forward Deceleration " drive decelerates with a forward direction of rotation.

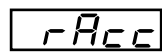

" Reverse Acceleration " drives accelerates with a reverse direction of rotation.

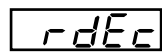

" Reverse Deceleration " drive decelerates with a reverse direction of rotation.

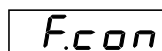

" Forward Constant " drive runs with a constant speed and a forward direction of rotation.

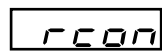

" Reverse Constant " drive runs with constant speed and a reverse direction of rotation.

Other status messages are described with the parameters which are related to them.

Actual load

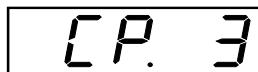

Display of the actual inverter loading in percent. 100% load is equal to the inverter rated current. Only positive values are displayed, meaning there is no differentiation between motor and regenerative operation.

Peak load

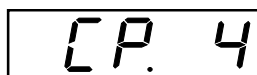

This display makes it possible to recognize instantaneous load levels by storing the highest value that occurred. The display occurs in percent (100% = inverter rated current).



With the UP or DOWN key the peak value can be reset. Switching off the unit deletes the peak value.

Operation of the Unit

2.5 Basic adjustment of the drive The following parameters determine the fundamental operating data of the drive. They should be checked and/or adjusted for the application.

Rated frequency



The inverter produces maximum voltage to the motor at the frequency set in this parameter. This parameter is typically adjusted for the motor rated frequency. **Note:** Motors can overheat when the rated frequency is incorrectly adjusted!



Adjustment range: 0...409.58 Hz
 Resolution: 0.0125 Hz
Factory setting: 50.0 Hz
 Customer adjustment: _____ Hz

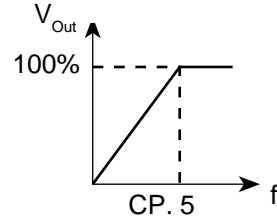

Boost



In the lower speed range losses in the motor become greater. This parameter can be used to boost the voltage in order to overcome these losses. With proper adjustment, the torque output of the motor will remain constant even at the lowest speeds.

Adjustment range: 0...25.5 %
 Resolution: 0.1 %
 Factory setting: 2.0 %
 Customer adjustment: _____ %

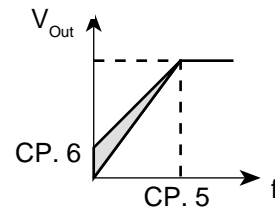

- Adjustment:
- Using CP.3, determine the load level during no-load operation at the rated frequency
 - Run the motor at 10 Hz and adjust the boost, so that the same load level occurs as at the rated frequency.
 - When the motor runs at low speeds continuously with too much boost, overheating of the motor can result.



Acceleration time

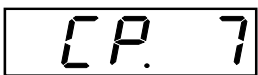

This parameter determines the time required to accelerate from 0 to 100 Hz. The actual acceleration time is proportional to the change in frequency. See below.

$$\text{actual acceleration time} = \frac{\text{change in frequency} \times \text{CP.7}}{100 \text{ Hz}}$$

Adjustment range: 0.01...300 s
 Resolution: 0.01 s
 Factory setting: 10 s
 Customer adjustment: _____ s

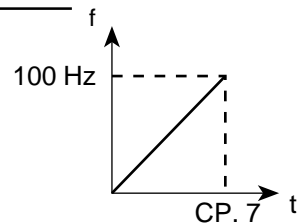

Example: CP. 7 = 10 s ; the drive accelerates from 10 Hz to 60 Hz
 change in frequency = 60 Hz - 10 Hz = 50 Hz
 actual acceleration time = (50 Hz / 100 Hz) x 10s = 5 s

Deceleration time

CP. 8

This parameter determines the time required to decelerate from 100 to 0 Hz. The actual deceleration time is proportional to the frequency change.

$$\text{actual deceleration time} = \frac{\text{change in frequency} \times \text{CP.8}}{100 \text{ Hz}}$$

Adjustment range: 0.01...300 s
 Resolution: 0.01 s
 Factory setting: 10 s
 Customer adjustment: _____ s

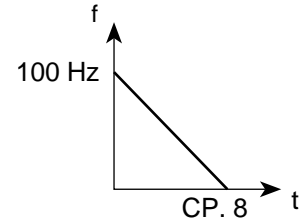

Example: CP. 8 = 10 s ; the drive should decelerate from 60 Hz to 10 Hz
 change in frequency = 60 Hz - 10 Hz = 50 Hz
 actual deceleration time = (50 Hz / 100 Hz) x 10s = 5 s

Minimum frequency

CP. 9

The frequency the inverter outputs with 0V applied to the analog input or if the activated fixed frequency (CP.11...CP.13) is lower than this value.

Adjustment range: 0.0...409.58 Hz
 Resolution: 0.0125 Hz
 Factory setting: 0.0 Hz
 Customer adjustment: _____ Hz

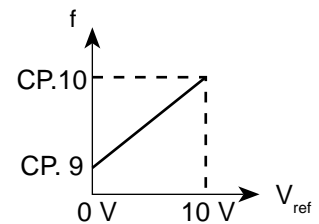

Maximum frequency

CP. 10

The frequency the inverter outputs with 10V applied to the analog input or if the activated fixed frequency (CP.11...CP.13) is greater than this value.

Adjustment range: 0.0...409.58 Hz
 Resolution: 0.0125 Hz
 Factory setting: 70 Hz
 Customer adjustment: _____ Hz

Fixed frequency 1...3

terminal X1.4

CP. 11

terminal X1.5

CP. 12

terminals X1.4+X1.5

CP. 13

Three fixed frequencies can be adjusted. The selection of the fixed frequencies is made with the terminals 4 and 5.

Adjustment range: 0.0...409.58 Hz
 Resolution: 0.0125 Hz
 Factory setting: 5/50/70 Hz
 Customer adjustment 1: _____ Hz
 Customer adjustment 2: _____ Hz
 Customer adjustment 3: _____ Hz

If the adjusted values are outside of the fixed limits of CP.9 and CP.10, then the actual run frequency will be either CP.9 or CP.10.

Operation of the Unit

2.6 Special adjustments

Max. ramp current

CP.14

The following parameters serve to optimize the inverter for the application. These adjustments can be ignored at initial start-up.

This function acts as an adjustable current limit during acceleration or deceleration. It can be used to prevent the load current from exceeding the inverter's peak current rating, thereby preventing shut down of the inverter with an E.O.C fault. When the load level reaches the adjusted value, the acceleration or deceleration is stopped until the load drops below the adjusted value. CP.2 displays "LAS" when the function is active.

Adjustment range: 10...200%, 200% = off housing size D
10...200%; >150%=off housing E and greater

Resolution: 1 %
Factory setting: 140 %
Customer adjustment: _____ %

Max. constant current

CP.15

This function acts as an adjustable current limit when operating at a constant speed. It can be used to prevent the load current from exceeding the inverter's over current level, thereby preventing shut down of the inverter with an E.O.C fault. When the load level reaches the adjusted value, the output frequency is reduced until the load drops below the adjusted value, after which the frequency is increased again to the previous value. CP.2 displays "SSL" when the function is active.

Adjustment range: 10...200%, 200% = off housing size D
10...200%; >150% = off housing E and greater

Resolution: 1 %
Factory Setting: 200 %
Customer adjustment: _____ %

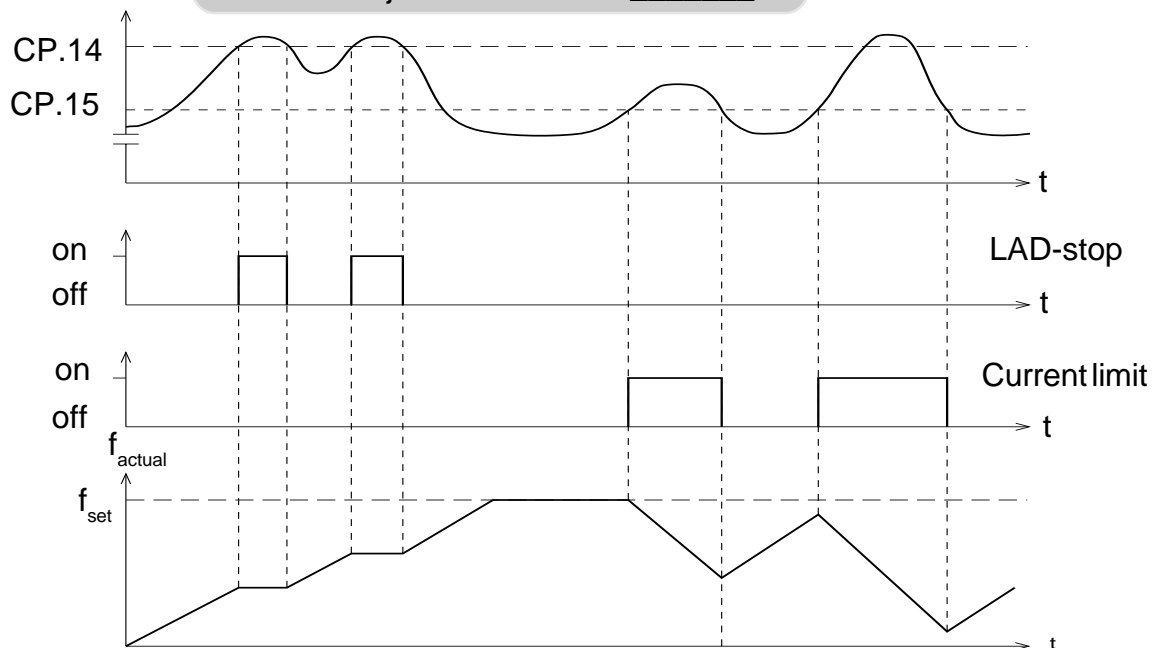

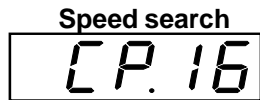

When starting the frequency inverter into a spinning motor, an E.OC fault can be triggered because of the difference between the actual motor speed and the inverter set speed. By activating speed search, the inverter searches for the actual motor speed, adjusts its output frequency to match. It will then accelerate with the adjusted ramp time to the given set value. During speed search CP.2 displays "SSF". This parameter determines under which conditions the function will operate.

Adjustment range: 0...15
 Resolution: 1
 Factory setting: 8
 Customer adjustment: _____

Value	Activation Condition
0	function off
1	control release turned on
2	power on
3	control release, power on
4	after fault reset
5	control release, after fault reset
6	power on, after fault reset
7	control release, power on, after fault reset
8	after autorestart (E.UP)
9	control release, after autorestart (E.UP)
10	power on, after autorestart (E.UP)
11	control release, power on, after autorestart (E.UP)
12	after fault reset, after autorestart (E.UP)
13	control release, after fault reset, after autorestart (E.UP)
14	power on, after fault reset, after autorestart (E.UP)
15	control release, power on, after fault reset, after autorestart (E.UP)

Operation of the Unit

Voltage stabilization

CP.17

This parameter can be used to regulate the output voltage in relation to the rated frequency. With this function active, voltage variations at the input as well as in the DC bus will have only a small influence on the output voltage (V/Hz-characteristic). The function can be used to adapt the output voltage for special motors. In the example below the output voltage is stabilized at 230 V (The graph shows 0% boost).

Adjustment range: 150...649 V, off
Resolution: 1 V
Factory setting: off
Customer adjustment: _____ V

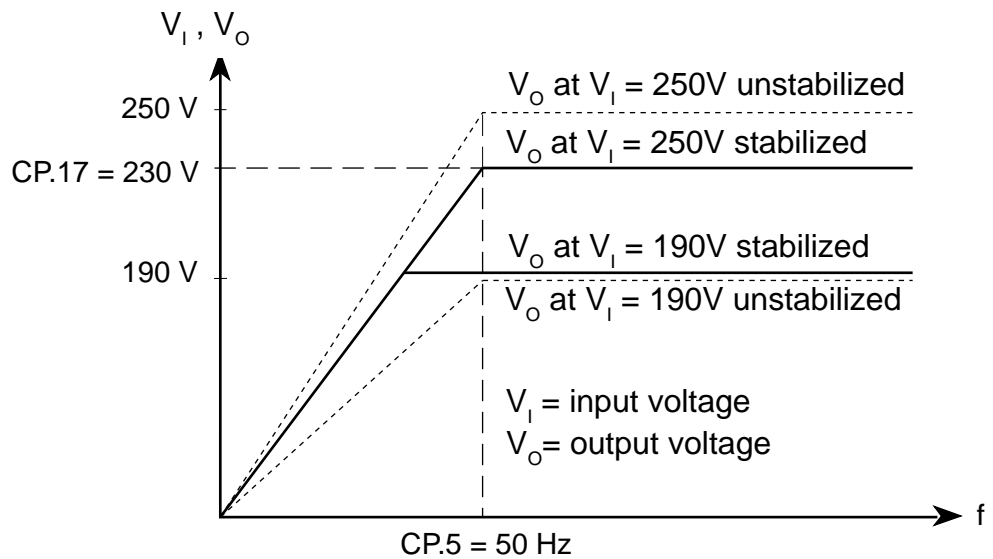

Slip compensation

CP.18

Slip compensation reduces speed variations caused by changes in the load. The function will increase the output frequency, as the load current of the motor increases, to maintain the same motor speed. To activate the function, set the value at 1.00 and optimize as directed in the diagram below

Adjustment range: -2.50...2.50
Resolution: 0.01
Factory setting: 0.00 (= off)
Customer adjustment: _____

Autoboost
CP.19

Autoboost gives automatic I*R-compensation. When the load torque increases, the additional resistive losses reduce the magnetizing current in the motor, leading to a reduction in motor speed. To compensate, auto boost can be used to automatically increase the applied motor voltage as the motor load increases. To activate the function set the value to 1.00 and optimize as directed below. After making an adjustment, check the response by monitoring the motor voltage. When the load is removed, the voltage should drop to a lower level. If it does not, reduce the value of CP.19.

Adjustment range: -2.50...2.50
 Resolution: 0.01
 Factory setting: 0.00 (= off)
 Customer adjustment: _____



Slip compensation and autoboost functions use a model of a standard motor equal in power to the inverter rating. When using a special motor or in case of inverter oversizing, then both functions should be deactivated.

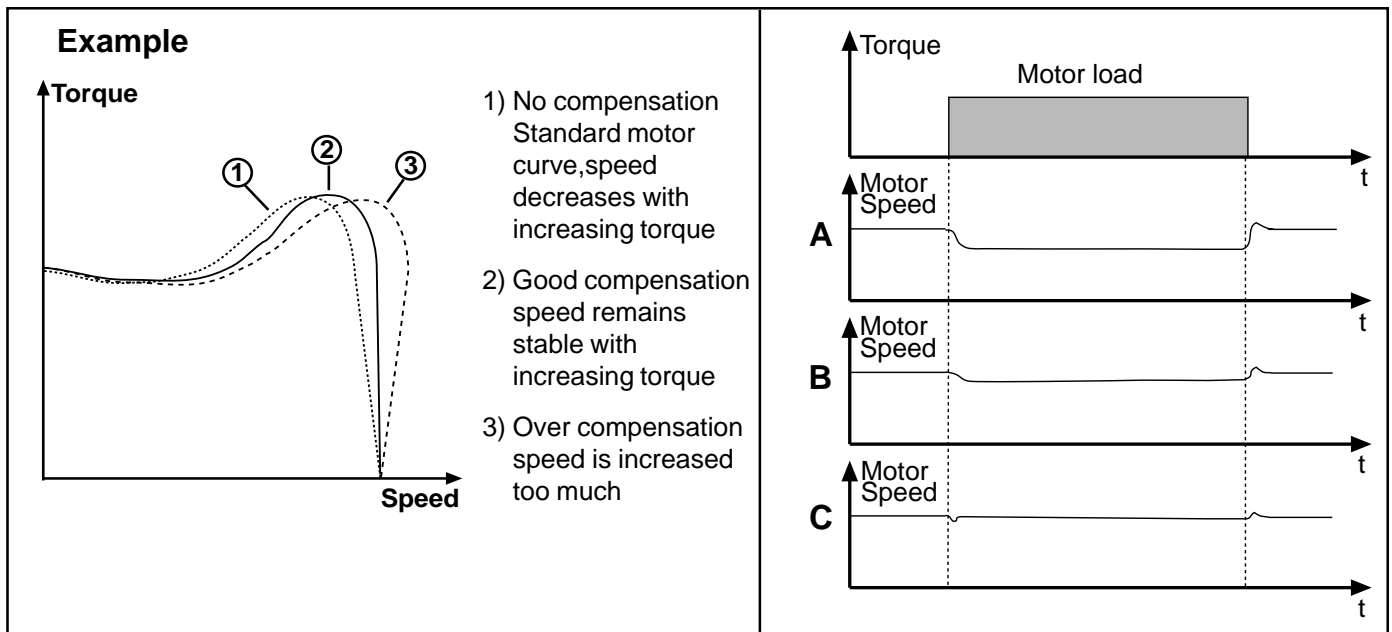

Slip compensation and autoboost adjustment steps see curves A,B,C above.

1. Measure "no load" speed with tachometer. Apply the load to the motor and the speed will drop as in curve A.
2. To begin compensation, set CP.18 and CP.19 to 1.00. Motor speed should increase.
3. If speed is still below "no load" value, increase CP.19. until speed does not change with further increase in CP.19. See curve B.
4. Increase CP.18 to compensate for the remaining speed difference. See curve C.
5. Verify output voltage drops when load is removed.

Operation of the Unit

DC-braking

CP.20

During DC-braking, the motor is not decelerated by a controlled ramp. Quick braking without regen voltage can be achieved by applying a DC voltage to the motor winding. This parameter determines how the DC-braking is triggered.

Value	Mode of Activation
0	DC-braking deactivated
1	DC-braking activates when direction signal is removed and the output frequency has reached 0Hz. Braking time is dependent on CP.21 or until a direction of rotation signal is given.
2	DC-braking activates as soon as the direction signal is removed. Braking time dependent on the actual frequency.
3	DC-braking, activates as soon as the direction of rotation changes. Braking time dependent on the actual frequency.
4	DC-braking activates when rotation signals are removed and the actual frequency goes below 4 Hz.
5	DC-braking, when the actual frequency goes below 4 Hz.
6	DC-braking, activates when the set value goes below 4 Hz.
7	DC-Braking is activated when a signal is present at I3 (terminal 6). Braking time is dependent on the actual frequency.
8	DC-Braking as long as a signal is present at I3(terminal 6)
9	DC-braking before the acceleration ramp when a direction signal is given. The time is dependent on CP.21.

Factory setting: 7
 Note: Enter-Parameter
 Customer adjustment: _____

Braking time

CP.21

The actual braking time is calculated using one of the two methods listed below. The value of CP.20 determines which one is used.

- entered time = braking time
- entered time relates to 100 Hz and increases/decreases proportionally to the actual frequency.

Adjustment range: 0.00...100 s
 Resolution: 0.01 s
 Factory setting: 10 s
 Customer adjustment: _____

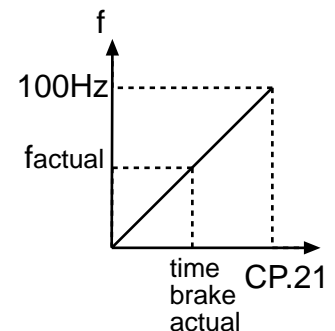

Calculation of the braking time:

$$t_{\text{brake actual}} = \frac{\text{CP.21} \times f_{\text{actual}}}{100 \text{ Hz}}$$

Relay output

CP.22

The relay output (terminals 1,2,3) is adjusted as a fault relay at the factory. This parameter can adjust the function of the output to any function listed in the table below.

Value	Function
0	No function
1	On when unit has voltage applied to it
2	Fault relay
3	Fault relay excluding under voltage (E.UP)
4	Overload alert signal (10s before inverter switch off)
5	Over temperature inverter alert signal
6	Over temperature motor alert signal (10s before switch off)
7	No function
8	Stall load level (CP.15) exceeded
9	LA-/LD-Stop load level (CP.14) exceeded
10	DC-braking active
11	No function
12	Load level (CP.3) > 100%
13	No function
14	Actual value=set value (CP.2 = Fcon or rcon only; not during noP, LS, error, SSF)
15	Acceleration (CP.2 = FAcc, rAcc, LAS)
16	Deceleration (CP.2 = FdEc, rdEc, LdS)
17	Forward rotation (not during noP, LS error)
18	Reverse rotation (not during noP, LS error)
19	Actual direction of rotation = set direction of rotation
20	Actual frequency > frequency level CP.23
21	Set frequency > frequency level CP.23
22	No function
23	Operating signal (active after initialization; off when fault occurs)
24	Run signal
25	No function

Factory setting: 2
 Note: Enter-Parameter
 Customer adjustment: _____

This parameter determines the frequency level at which the relay output (terminals 21,22,23) switches

Frequency level

CP.23

After the switching of the relay, the frequency can move within a 0.5 Hz window, without the relay changing states.

Adjustment range: 0.0...409.58 Hz
 Resolution: 0.0125 Hz
 Factory setting: 4 Hz
 Customer adjustment: _____

Operation of the Unit

Reference signal



The analog input REF (terminal 17) can be driven by different types of signals. The signal at REF is added to the differential signal applied to terminals 8 and 9. When nothing is connected to terminals 8 and 9, REF serves as the only analog input source. Through this parameter the input can be configured for the analog signals listed below.

Value	Analog reference signal
0	0...10VDC / input resistance = 4K ohm
1	0...20mADC / input resistance = 250 ohm
2	4...20mADC / input resistance = 250 ohm

Factory setting 0
Customer adjustment _____

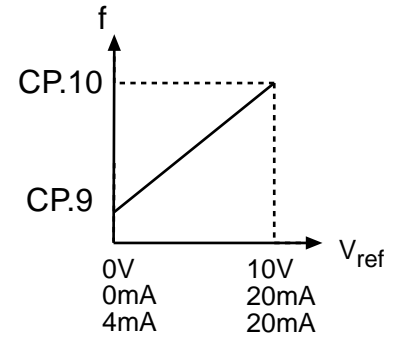

2.7 The "Drive Mode" The drive mode is an operating mode of the COMBIVERT F4-C used to start the drive manually through the digital operator. After applying a signal to the control release terminal 14, the set frequency and rotation direction is adjusted by the buttons on the digital operator. In order to activate the drive mode, a **password in CP.0** must be entered. See page 24 for password information. The display changes as follows.

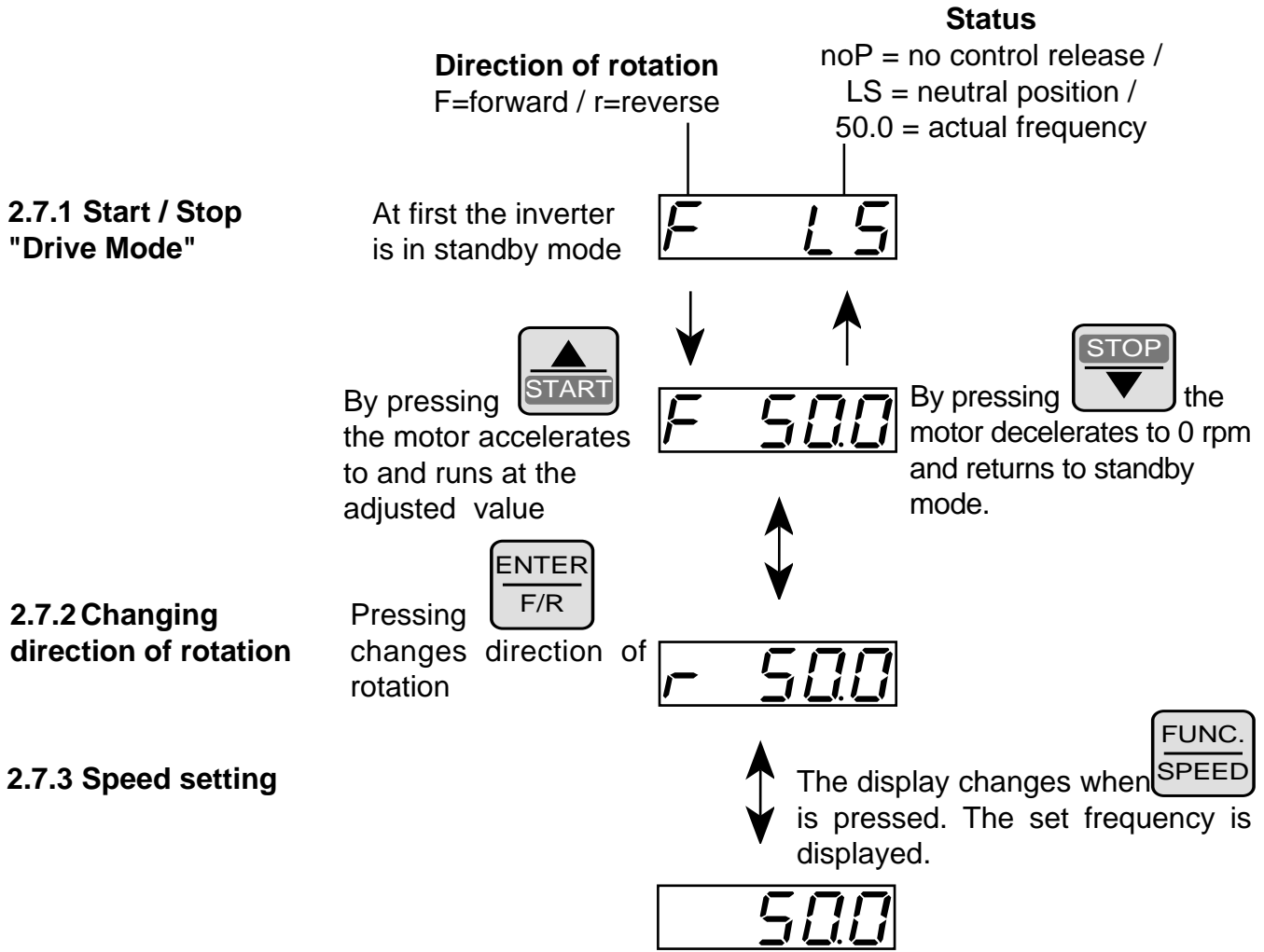

The set frequency can be changed by pressing or while holding the key down.

2.7.4 Leaving "Drive Mode" To exit the drive mode the inverter must be in standby (display shows noP or LS). Press the FUNC and ENTER keys simultaneously for about 3 seconds in order to leave the drive mode. The CP-parameters appear in the display.

+ for 3 seconds

2.8 The "Application Mode"

The "application mode" offers the user an advanced level for programming the inverter. By entering the application mode a different parameter structure is activated. The CP parameters are replaced with different parameter groups. Using these parameter groups and the parameters therein, the user can customize the inverter for given application.

The following functions can be accessed through the "application mode."

- Advanced speed adjustment settings (multiple set speeds, acceleration and deceleration rates, S-curves, push button potentiometer function)
- Power Off feature - quickly stops motor in the event of input voltage loss
- Built in digital PI controller for closed loop speed/process regulation
- Special winding and tension control functions
- Advanced I/O handling including custom definable functions, software timers, edge triggered signals, adjustable trigger levels
- Custom programmable analog inputs and outputs
- Customer definable CP parameters
- Multiple motor set up and custom V/F curves

A separate instruction manual is available for working with the application mode. Please consult KEBCO for additional information.

Computer software can be provided in either DOS or Windows™ to assist with parameter adjustment and monitoring. Contact KEBCO for a free copy of this software.

3. Error diagnosis

Error messages are represented with an "E. " followed by a code that defines the type of error. When an error occurs, inverter operation stops and the motor is no longer controlled by the inverter. The errors and their causes are described below.

Undervoltage

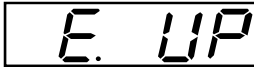

Occurs, when the DC bus voltage falls below the permissible value.
(for 230V units 255VDC, for 460V units 425VDC)

Possible Causes	Possible solutions
- input voltage too low or unstable	- install boosting transformer to increase voltage
- inverter sized too small for given load	- step up to next larger sized inverter
- missing input phase or input not connected properly	- check protective fusing for blown fuses, verify connections
- connection to an unbalanced supply (i.e. corner ground delta)	- install Δ to Y isolation transformer between inverter and main supply voltage

Overvoltage



Occurs, when the DC bus voltage rises above the permissible value.
(for 230V units 400VDC, for 460V units 800VDC)

Possible Causes	Possible solutions
- input voltage too high	- install buck transformer to decrease voltage
- voltage spikes on supply voltage	- install line choke on input to inverter
- PF correction capacitor switching at sub-station	- install buck transformer or choke on inverter input
- deceleration time too short and or braking resistor not connected.	- lengthen decel time or add/connect braking resistor

Overcurrent

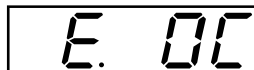

Occurs, when the peak current level of the inverter has been exceeded or during a ground fault condition. For specific current levels consult the power stage instruction manual and refer to the technical data section.

Possible causes	Possible solutions
- motor larger than recommended for inverter size	- increase size of inverter, consult inverter specifications
- acceleration or deceleration times too short	- lengthen times and/or activate LAD stop function (CP.14)
- voltage boost (CP.6) set too high	- lower adjusted value
- rated frequency (CP.5) of inverter is not adjusted correctly	- check motor rated frequency and adjust inverter rated frequency the same except in case listed below
- 50 Hz 400V motor running on inverter connected to 480V	- change rated frequency from 50Hz to 60 Hz when input voltage is 460V or greater

Overload

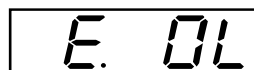

Occurs when inverter load is greater than 105% for longer than the allowable time. Consult inverter specifications. See also E.nOL .

Possible causes	Possible solutions
- motor larger than recommended for inverter size	- increase size of inverter, consult inverter specifications
- increased friction or jam in the mechanical system	- check machine for wear, clear obstructions
- motor incorrectly wired	- verify motor connection
- rated frequency (CP.5) of inverter is not adjusted correctly	- check motor rated frequency and adjust inverter rated frequency the same except in case listed below
- 50 Hz 400V motor running on inverter connected to 480V	- change rated frequency from 50Hz to 60 Hz when input voltage is 460V or greater

Error Diagnosis

Cooling down phase completed

E.nOL

After an E.OL error you must wait for the inverter to cool down. This message appears after the cooling down phase is completed. The E.OL error can only be reset after this message is displayed. Removing the supply voltage will not defeat the cool down period; leave supply voltage on until message is displayed.

Overheat

E. OH

Occurs, when the inverter heat sink temperature is greater than 158°F.

Possible Causes	Possible solutions
- insufficient cooling	- observe proper mounting clearances
- insufficient cooling	- clear heatsink of all dirt and debris
- ambient temperature too high	- install cooling device to reduce air temp below 113°F
- cooling fan (when installed) not functioning	- check for fan obstructions, blades should spin freely.

Overheat motor

E.dOH

Occurs when resistance between "OH terminals becomes greater than 1650 ohms.

Possible Causes	Possible solutions
- factory jumper loose (not using this function)	- tighten black jumper wire between OH terminals
- ambient temperature around motor too high	- install cooling device to reduce air temp
- motor overload, see E.OC and E.OL causes	- see E.OC and E.OL solutions
- Motor temperature sensor cable broken	- repair cable

Overheat cleared

E.nOH

Internal or external temperature has dropped to a safe level. Error "E. OH" can be reset.

Charging relay error

E.LSF

Occurs when the charging relay does not close after the DC bus voltage reaches its normal operating level.

Possible Causes	Possible solutions
- see causes listed under E.UP	- see solutions listed under E.UP
- charge relay or charge resistor has failed	- replace unit with new unit and return old unit for repair

4. Glossary

Analog/Digital Common The COMBIVERT F4-C has potential separated (galvanically isolated) digital inputs and power supply. With this design, electrical noise and leakage currents are greatly reduced. As a result, the digital common (13) serves as a reference for the power supply and all digital inputs. The analog common (18) serves only as a common for the analog signals. For best results, it is important to avoid connecting these two commons together.

EMC **Electro-** magnetic compatibility, guidelines for reducing high frequency interference caused by the inverter.

Energy-Saving Function When motors are running under "no-load" conditions, the voltage can be reduced, and as a result energy can be saved.

Frequency-dependent Switch Relay or transistor output that activates at a preset frequency.

Actual Value A value that is measured by sensors in the inverter or a value that is calculated from a measured value and a pre-existing condition.

LA-Stop Acceleration stop, prevents over current errors during acceleration by stopping the ramp. The current level is specified by the max. ramp current (CP.14).

RS232/485 RS232, is the standard serial interface for connection between an inverter and computer or PLC with a cable length of 45 feet maximum . RS485, is the standard serial interface for multiple inverters connected to a computer or PLC . Maximum cable length is 3000 feet.

Set Value The preset analog or digital value with which the frequency inverter shall operate.

Speed Search Speed search prevents an over current error when starting the inverter into a running motor. The motor speed is determined and the inverter begins to accelerate the motor at this frequency.

Stall The Stall-function protects the inverter against an E.OC error while running at a constant speed. When exceeding the level adjusted with CP.15, the output frequency is reduced until the load level drops below the level in CP.15.

NOTES:

5. Quick reference

Display	Parameter	Adjust. range	Resolution	Customer setting
CP. 0	Password input	0...9999	1	-
CP. 1	Actual frequency display	Read only	0.1 Hz	-
CP. 2	Inverter status display	Read only	-	-
CP. 3	Actual load	Read only	1 %	-
CP. 4	Peak load	Read only	1 %	-
CP. 5	Rated frequency	0...409.58 Hz	0.0125 Hz	_____
CP. 6	Boost	0...25.5 %	0.1 %	_____
CP. 7	Acceleration time	0.01...300 s	0.01 s	_____
CP. 8	Deceleration time	0.01...300 s	0.01 s	_____
CP. 9	Minimum frequency	0...409.58 Hz	0.0125 Hz	_____
CP.10	Maximum frequency	0...409.58 Hz	0.0125 Hz	_____
CP.11	Fixed frequency 1	0...409.58 Hz	0.0125 Hz	_____
CP.12	Fixed frequency 2	0...409.58 Hz	0.0125 Hz	_____
CP.13	Fixed frequency 3	0...409.58 Hz	0.0125 Hz	_____
CP.14	Max. ramp current	10...200 %	1 %	_____
CP.15	Max. constant current	10...200 %	1 %	_____
CP.16	Speed search	0...7	1	_____
CP.17	Voltage stabilization	150...649 V,oFF	1 V	_____
CP.18	Slip compensation	-2.50...2.50	0.01	_____
CP.19	Autoboost	-2.50...2.50	0.01	_____
CP.20	DC-braking	0...9	1	_____
CP.21	Braking time	0...100 s	0.01 s	_____
CP.22	Relay output	0...25	1	_____
CP.23	Frequency level	0...409.58 Hz	0.0125 Hz	_____
CP.24	Reference Signal	0..2	1	_____

The **function key** (FUNC) changes between the parameter value and parameter name.



With **UP** (▲) and **DOWN** (▼), the value of the parameter or the parameter number is increased/decreased. The values of "Read Only Parameters" can not be changed.

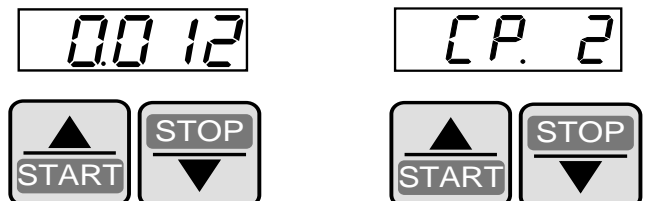

6. Passwords

A - locking the CP-Parameters from change (read only)

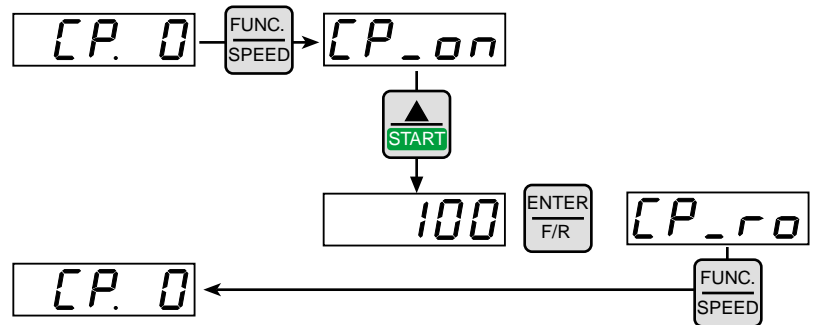

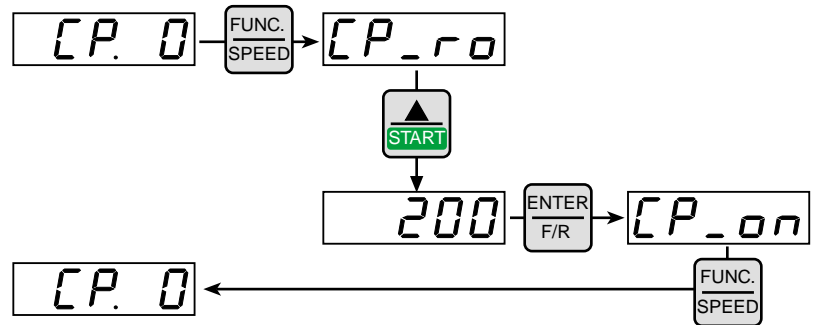

B - Releasing the CP-Parameters, allowing changes

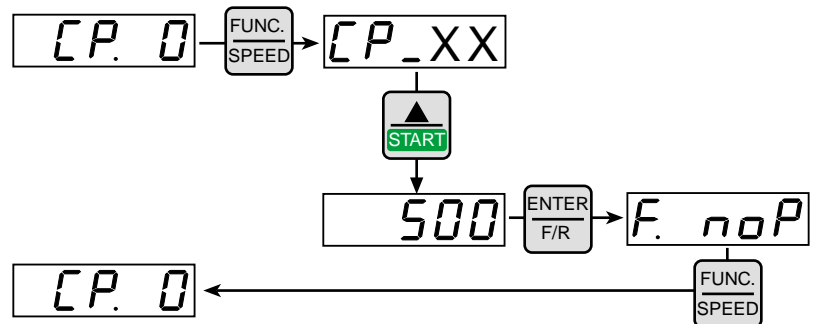

C - Activating "Drive Mode"



D - Leaving "Drive Mode"

 +  for 3 seconds

Special Notice to Customer

Prior to delivery all products pass several quality and performance inspections in order to guarantee the product is free from defects in manufacturing. When used in accordance with the operating instructions, failure of the unit is not likely. However, if you have reason for concern please contact KEBCO at 800-899-3226 and ask for inverter technical support. From this point our technical support engineers can help you determine the cause of the problems and also the proper solution.

Listed values in this manual are standard values only and do not pertain to special units. We reserve the right to make technical changes without notification.

KEBCO Limited Warranty

KEBCO will repair or replace, at KEBCO's discretion, any inverter which shows signs of defect in material, workmanship or fails to meet factory specifications within one year from original date of shipment from KEBCO in St. Paul. The serial number will be used to track the shipping date. Operation of the inverter outside the rated specifications printed in the instruction manuals will void the warranty.

KEBCO does not assume any liability (cost of removal, cost of installation, down time, production delays, or damage to other items associated with the inverter) for failures which occur during or after the warranty period.

To make a warranty claim contact the Electronic repair department at the number listed above, and request a Return Goods Authorization (RGA) number. The inverter is to be shipped prepaid to the address listed below. Suitable packaging must be provided to prevent the inverter from incurring damages during shipping as damages of this nature will void the warranty.

KEBCO will inspect the inverter to determine the cause of the problems in the inverter and will repair or replace the inverter at its discretion.

KEBCO Inc.
Attn. ELECTRONIC REPAIR (RGA#)
1335 Mendota Heights Road
St. Paul, MN 55120



POWER TRANSMISSION

KEBCO Inc. • USA Headquarters
1335 Mendota Heights Road
St. Paul, MN 55120
PH:800-899-3226 / 651-454-6162
FAX:651-454-6198
WEB:www.kebco.com

With Sales Offices in:
Atlanta, Georgia
Columbus, Ohio
Dallas, Texas